



# ST-S ストレートシャンク 焼きばめホルダ

STRAIGHT SHANK SHRINK FIT HOLDER



## 特長 Features

- ◆ 把握力はコレットチャックの3倍  
3 times higher clamping force compared to collet chuck
- ◆ 細身で干渉が少ない。  
Slim design for less interference
- ◆ 高バランス形状高速加工に最適。  
High balanced design for high speed machining
- ◆ 抜群の振れ精度3D先端で $3\mu\text{m}$ 以下。  
Runout is less than  $3\mu\text{m}$  at 3D end.
- ◆ 長さの調整が自由自在。

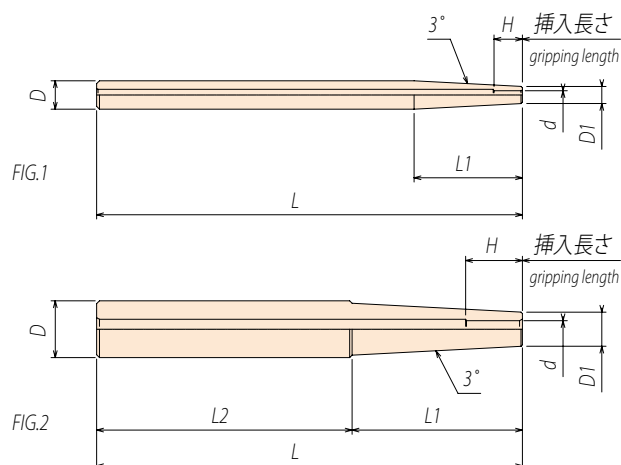

CODE	FIG	$\phi d$	$\phi D$	$\phi D1$	L	L1	L2	H			
ST10-S 3 -100	1	3	10	6	100	38	-	10			
ST10-S 3 -150			150		-						
ST16-S 3 -150	2	3	16	6	100	50	50	10			
ST20-S 3 -100			150		80	70					
ST20-S 3 -150			200		120	80					
ST20-S 3 -200			150		70	80					
ST16-S 4 -150		2	4	16	7	150	60	90	12		
ST20-S 6 -150			6	20	12				20		
ST20-S 8 -150			8	20	14				25		
ST25-S10 -150			10	25	16				30		
ST25-S10 -200			12	32	20					70	130
ST32-S12 -200					25					100	100
ST32-S16 -200	16	25			80	120					
ST32-S20 -200	1	20	29	200	28.6	-	35	40			

■ 特殊サイズも注文により製作いたします。 Special size is available upon request.