



# ST-MRC ストレートシャンクコレットチャック

STRAIGHT SHANK COLLET CHUCK



ミーリングチャック、コレットチャックで使用していただけます。

長さ方向の調整が自由自在

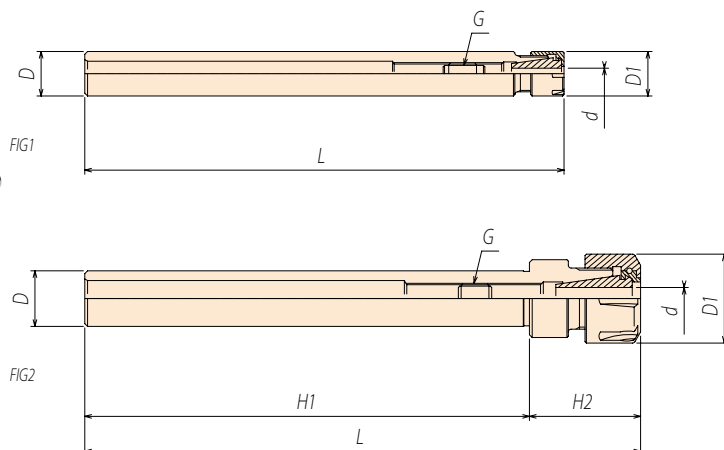

CODE		FIG	$\phi d$	D	$\phi D1$	L	H1	H2	G
ST12-MRC5	-150	1	0.2 ~ 5.0	12	12	150	-	-	M6 × P1.0
ST16-MRC7	-150		0.2 ~ 7.0	16	16		M8 × P1.0		
ST20-MRC10	-200	2	0.5 ~ 10.0	20	28	200	160	40	M11 × P1.0
ST32-MRC13	-200	1	1.0 ~ 13.0	32	35		-	-	M15 × P1.5
ST32-MRC16	-200	2	1.0 ~ 16.0		42		150	50	M18 × P1.5
ST32-MRC20	-200		2.0 ~ 20.0	50	145		55	M22 × P1.5	

■ナットは付属していますが、コレット、レンチは別途ご注文ください。  
 小径用コレットMRC5、MRC7 P35 普通コレットMRC10~MRC20 P35 タップコレット P37  
 Comes with collet nut, purchase collet & wrench separately.

# ST-MRC F ストレートシャンクコレットチャック

STRAIGHT SHANK COLLET CHUCK

旋盤、複合加工機用ホルダ

高精度ドリル加工、リーマ加工に最適。

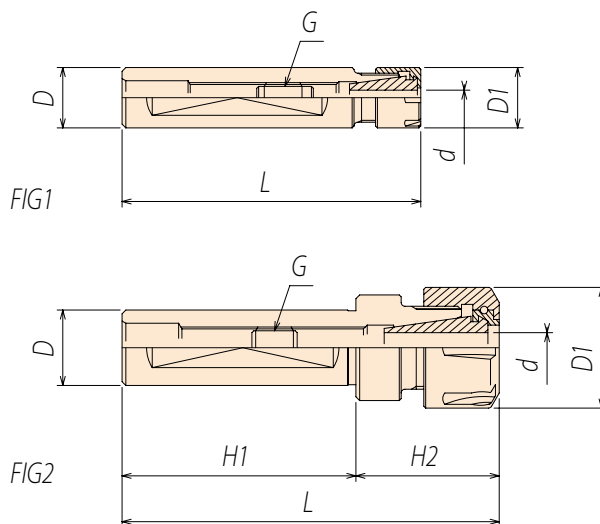

CODE		FIG	$\phi d$	D	$\phi D1$	L	H1	H2	G
ST16F-MRC7	- 80	1	0.2 ~ 7.0	16	16	80	-	-	M8 × P1.0
ST20F-MRC10	-100	2	0.5 ~ 10.0	20	28	100	62	38	M11 × P1.0
ST32F-MRC13	-100	1	1.0 ~ 13.0	32	35		-	-	M15 × P1.5
ST32F-MRC16	-120	2	1.0 ~ 16.0		42	120	80	40	M18 × P1.5
ST32F-MRC20	-130		2.0 ~ 20.0	50	130	80	50	M22 × P1.5	

■ナットは付属していますが、コレット、レンチは別途ご注文ください。  
 小径用コレットMRC7 P35 普通コレットMRC10~MRC20 P35 タップコレット P37  
 Comes with collet nut, purchase collet & wrench separately.



# MRC 小径用精密コレット

MICRO PRECISION COLLET



## 超小径マイクロボアコレット MICRO BORE COLLET



径 mm	MRC5-MB	MRC7-MB
0.2	MRC5-MB02	MRC7-MB02
0.3	MRC5-MB03	MRC7-MB03
0.4	MRC5-MB04	MRC7-MB04
0.5	MRC5-MB05	MRC7-MB05
0.6	MRC5-MB06	MRC7-MB06
0.7	MRC5-MB07	MRC7-MB07
0.8	MRC5-MB08	MRC7-MB08
0.9	MRC5-MB09	MRC7-MB09

■呼び径のみクランプでき、把握範囲はございません。  
Only available in nominal diameter. There is no chucking range.

## 小径コレット SMALL DIA. COLLET

径 mm	MRC5		MRC7	
	普通級 Standard collet	精度級 Precision collet	普通級 Standard collet	精度級 Precision collet
0.5 ~ 1.0	MRC5-1	MRC5-U 1	MRC7-1	MRC7-U 1
1.0 ~ 1.5	MRC5-1.5	MRC5-U 1.5	MRC7-1.5	MRC7-U 1.5
1.5 ~ 2.0	MRC5-2	MRC5-U 2	MRC7-2	MRC7-U 2
2.0 ~ 2.5	MRC5-2.5	MRC5-U 2.5	MRC7-2.5	MRC7-U 2.5
2.5 ~ 3.0	MRC5-3	MRC5-U 3	MRC7-3	MRC7-U 3
3.0 ~ 3.5	MRC5-3.5	MRC5-U 3.5	MRC7-3.5	MRC7-U 3.5
3.5 ~ 4.0	MRC5-4	MRC5-U 4	MRC7-4	MRC7-U 4
4.0 ~ 4.5	MRC5-4.5	MRC5-U 4.5	MRC7-4.5	MRC7-U 4.5
4.5 ~ 5.0	MRC5-5	MRC5-U 5	MRC7-5	MRC7-U 5
5.0 ~ 5.5	-	-	MRC7-5.5	MRC7-U 5.5
5.5 ~ 6.0	-	-	MRC7-6	MRC7-U 6
6.0 ~ 6.5	-	-	MRC7-6.5	MRC7-U 6.5
6.5 ~ 7.0	-	-	MRC7-7	MRC7-U 7

## MRC コレット

### STANDARD COLLET

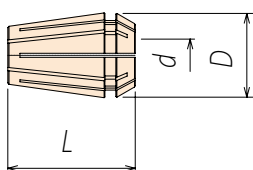

	外径 D	長さ L
MRC10	17	27.5
MRC13	21	31.5
MRC16	26	34
MRC20	33	40

■コレットに角を施したタップ専用コレットもあります。 Also available collet for tapping.

MRC10		MRC13		MRC16		MRC20	
把握範囲 Chucking range 0.5 ~ 10.0mm		把握範囲 Chucking range 1.0 ~ 13.0mm		把握範囲 Chucking range 1.0 ~ 16.0mm		把握範囲 Chucking range 2.0 ~ 20.0mm	
CODE	径 d	CODE	径 d	CODE	径 d	CODE	径 d
MRC10-1	0.5 ~ 1.	MRC13-2	1. ~ 2.	MRC16-2	1. ~ 2.	MRC20-3	2. ~ 3.
MRC10-2	1. ~ 2.	MRC13-3	2. ~ 3.	MRC16-3	2. ~ 3.	MRC20-4	3. ~ 4.
MRC10-3	2. ~ 3.	MRC13-4	3. ~ 4.	MRC16-4	3. ~ 4.	MRC20-5	4. ~ 5.
MRC10-4	3. ~ 4.	MRC13-5	4. ~ 5.	MRC16-5	4. ~ 5.	MRC20-6	5. ~ 6.
MRC10-5	4. ~ 5.	MRC13-6	5. ~ 6.	MRC16-6	5. ~ 6.	MRC20-7	6. ~ 7.
MRC10-6	5. ~ 6.	MRC13-7	6. ~ 7.	MRC16-7	6. ~ 7.	MRC20-8	7. ~ 8.
MRC10-7	6. ~ 7.	MRC13-8	7. ~ 8.	MRC16-8	7. ~ 8.	MRC20-9	8. ~ 9.
MRC10-8	7. ~ 8.	MRC13-9	8. ~ 9.	MRC16-9	8. ~ 9.	MRC20-10	9. ~ 10.
MRC10-9	8. ~ 9.	MRC13-10	9. ~ 10.	MRC16-10	9. ~ 10.	MRC20-11	10. ~ 11.
MRC10-10	9. ~ 10.	MRC13-11	10. ~ 11.	MRC16-11	10. ~ 11.	MRC20-12	11. ~ 12.
		MRC13-12	11. ~ 12.	MRC16-12	11. ~ 12.	MRC20-13	12. ~ 13.
		MRC13-13	12. ~ 13.	MRC16-13	12. ~ 13.	MRC20-14	13. ~ 14.
				MRC16-14	13. ~ 14.	MRC20-15	14. ~ 15.
				MRC16-15	14. ~ 15.	MRC20-16	15. ~ 16.
				MRC16-16	15. ~ 16.	MRC20-17	16. ~ 17.
						MRC20-18	17. ~ 18.
						MRC20-19	18. ~ 19.
						MRC20-20	19. ~ 20.



# MRC タップコレット

## STANDARD TAP COLLET



- ◆ コレット内径に角穴を施したタップ滑りに強いタップ専用コレット高精度タッピング加工に最適。

Special designed collets for high accurate tapping with special square bore in collet I.D. to avoid slip during tapping.

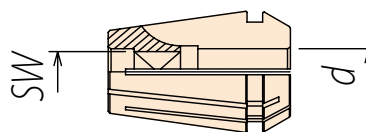
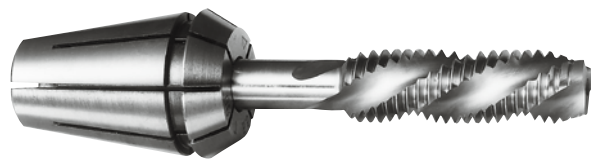

Tap Size	φ d	□ SW	(ER11-GB)	(ER16-GB)	(ER20-GB)	(ER25-GB)	(ER32-GB)
M3 ~ M3.5	4	3.2	MRC7	MRC10	MRC13	MRC16	MRC20
M4 ~ M4.5	5	4	MRC7-M 3	MRC10-M 3	MRC13-M 3	MRC16-M 3	MRC20-M 3
M5	5.5	4.5	-	MRC10-M 4	MRC13-M 4	MRC16-M 4	MRC20-M 4
M6	6	4.5	-	MRC10-M 5	MRC13-M 5	MRC16-M 5	MRC20-M 5
M7 ~ M8	6.2	5	MRC7-M 6	MRC10-M 6	MRC13-M 6	MRC16-M 6	MRC20-M 6
M9 ~ M10	7	5.5	-	MRC10-M 8	MRC13-M 8	MRC16-M 8	MRC20-M 8
M11	8	6	-	MRC10-M10	MRC13-M10	MRC16-M10	MRC20-M10
PT1/8-28	8	6	-	MRC10-M11	MRC13-M11	MRC16-M11	MRC20-M11
M12	8.5	6.5	-	MRC10-PT1/8	MRC13-PT1/8	MRC16-PT1/8	MRC20-PT1/8
M14 ~ M15	10.5	8	-	MRC10-M12	MRC13-M12	MRC16-M12	MRC20-M12
PT1/4-19	11	9	-	-	MRC13-M14	MRC16-M14	MRC20-M14
M16	12.5	10	-	-	MRC13-PT1/4	MRC16-PT1/4	MRC20-PT1/4
M18	14	11	-	-	-	MRC16-M16	MRC20-M16
PT3/8-19	14	11	-	-	-	MRC16-M18	MRC20-M18
M20	15	12	-	-	-	MRC16-M18	MRC20-M18
M22	17	13	-	-	-	MRC16-M20	MRC20-M20
PT1/2-14	18	14	-	-	-	-	MRC20-M22
M26 ~ M27	20	15	-	-	-	-	MRC20-PT1/2
			-	-	-	-	MRC20-M27

※ PT と PF シャンク同じ

## OSGシンクロタップ用

Tap Size	φ d	□ SW	(ER11-GB)	(ER16-GB)	(ER20-GB)	(ER25-GB)	(ER32-GB)
M3	4	3.2	MRC7	MRC10	MRC13	MRC16	MRC20
M4 ~ M6	6	4.5	MRC7-M 3	MRC10-M 3	MRC13-M 3	MRC16-M 3	MRC20-M 3
M8 ~ M10	8	6	MRC7-M 6	MRC10-M 6	MRC13-M 6	MRC16-M 6	MRC20-M 6
M12	10	8	-	MRC10-M11	MRC13-M11	MRC16-M11	MRC20-M11
M14	12	9	-	MRC10-M φ 10	MRC13-M φ 10	MRC16-M φ 10	MRC20-M φ 10
M16	16	12	-	MRC10-M φ 12	MRC13-M φ 12	MRC16-M φ 12	MRC20-M φ 12
			-	-	-	-	MRC20-M φ 16

## 超高速回転用 Mini ナット

### MINI NUT FOR HIGH SPEED



CODE	適用するホルダ Holder Size
ER-8MS	MRC5
ER-11MS	MRC7

## 小径コレットチャック用 レンチ

### WRENCH FOR SMALL SIZE COLLET CHUCK

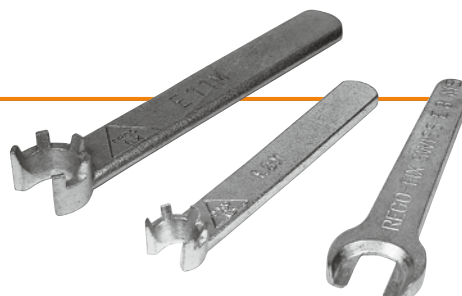

CODE	高速 Mini ナット用 Mini Nut Size	適合するホルダ Holder Size
E8M	E8MS	MRC5
E11M	E11MS	MRC7