



MTC 超ロングスリムチャックホルダ

SUPER LONG SLIM CHUCK HOLDER



特長 Features

- ◆ 干渉を考慮した胴径スリムチャック仕様。
Less interference with slim body.
- ◆ 深い穴加工に標準ドリルを使用出来コスト削減が可能になります。
Standard drill can be used for deep hole drilling. It helps cost reduction.
- ◆ 抜群の振れ精度5 μ m以下。
High precision. (less than 5 μ m)
- ◆ 刃物脱着が容易、高価な専用装置が不要です。
Easy chucking and removing.
No expensive special equipment required.
- ◆ シンプル構造で作業性UP。
Workability improvement with simple structure.
- ◆ エンドミル用は金型仕上加工に最適。
Endmill type is ideal for finishing of die and mold.

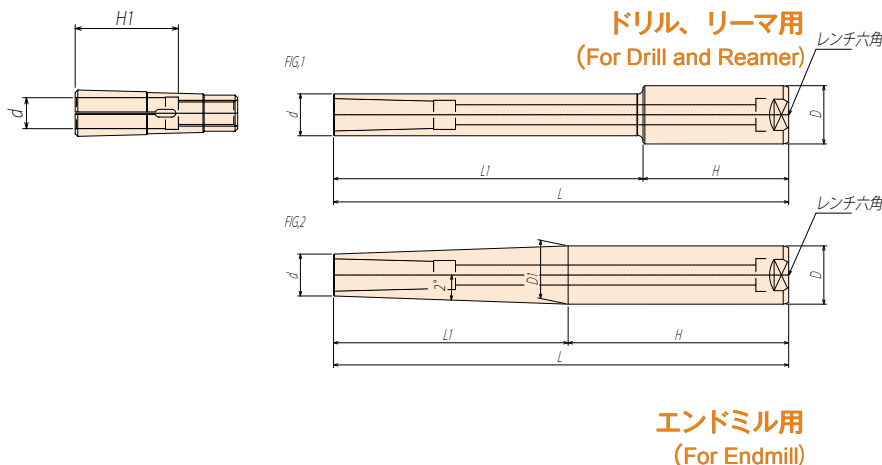

MTC コレット (Collet)

CODE	d	H1
MTC 8-6	6	26
-8	8	
MTC 12-6	6	30
-8	8	
-10	10	40
-12	12	
MTC 20-6	6	30
-8	8	
-10	10	45
-12	12	
-16	16	55
-20	20	

ドリル、リーマ用 (For Drill and Reamer)

■ Recommended tightening torque.

CODE	FIG	d	D	L	L1	H	Collet	Wrench	推奨締付トルク値
ST20-MTC 8-100	1	17	20	100	40	60	MTC8	5mm 六角	6 ~ 8Nm
-150				150	90				
-200				200	140				
ST32-MTC 12-150				23	32				
-200	200	120							
-250	250	170							
-300	300	220							
ST32-MTC 20-200	40	32	32	200	120	80	MTC20	14mm 六角	40 ~ 50Nm
-250				250	170				
-300				300	220				
-350				350	270				

エンドミル用 (For Endmill)

■ Recommended tightening torque.

CODE	FIG	d	D	L	L1	H	D1	Collet	Wrench	推奨締付トルク値
ST20-MTC 8E-100	2	17	20	100	43	57	20	MTC8	5mm 六角	6 ~ 8Nm
-150				107						
-200				157						
ST32-MTC 12E-150	23	32	32	150	129	80	32	MTC12	8mm 六角	10 ~ 15Nm
-200				71						
-250				121						
-300				171						
ST32-MTC 20E-200	40	32	32	200	200	80	47	MTC20	14mm 六角	40 ~ 50Nm
-250				170						
ST42-MTC 20E-300				42		42				
-350	58									

■ 特殊サイズも注文により製作いたします。 Special size is available upon request.